

AXOR[®]

hansgrohe

DE Gebrauchsanleitung / Montageanleitung	2
FR Mode d'emploi / Instructions de montage	2
EN Instructions for use / assembly instructions	3
IT Istruzioni per l'uso / Istruzioni per Installazione	3
ES Modo de empleo / Instrucciones de montaje	4
NL Gebruiksaanwijzing / Handleiding	4
DK Brugsanvisning / Monteringsvejledning	5
PT Instruções para uso / Manual de Instalação	5
PL Instrukcja obsługi / Instrukcja montażu	6
CS Návod k použití / Montážní návod	6
SK Návod na použitie / Montážny návod	7
ZH 用户手册 / 组装说明	7
RU Руководство пользователя / Инструкция по монтажу	8
HU Használati útmutató / Szerelési útmutató	8
FI Käyttöohje / Asennusohje	9
SV Bruksanvisning / Monteringsanvisning	9
LT Vartotojo instrukcija / Montavimo instrukcijos	10
HR Upute za uporabu / Uputstva za instalaciju	10
TR Kullanım kılavuzu / Montaj kılavuzu	11
RO Manual de utilizare / Instrucțiuni de montare	11
EL Οδηγίες χρήσης / Οδηγία συναρμολόγησης	12
SL Navodilo za uporabo / Navodila za montažo	12
ET Kasutusjuhend / Paigaldusjuhend	13
LV Lietošanas pamācība / Montāžas instrukcija	13
SR Uputstvo za upotrebu / Uputstvo za montažu	14
NO Bruksanvisning / Montasjeveiledning	14
BG Инструкция за употреба / Ръководство за монтаж	15
SQ Udhëzuesi i përdorimit / Udhëzime rreth montimit	15
AR دليل الاستخدام / تعليمات التجميع	16

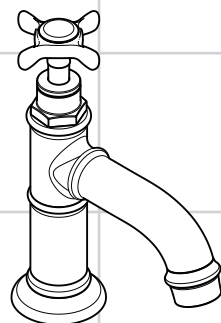

Montreux
16530XXX

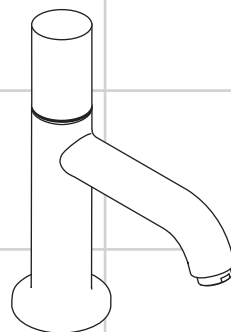

Uno
38130XXX



Sicherheitshinweise

- Bei der Montage müssen zur Vermeidung von Quetsch- und Schnittverletzungen Handschuhe getragen werden.
- Das Produkt darf nur zu Bade-, Hygiene- und Körperreinigungszwecken eingesetzt werden.

Montagehinweise

- Vor der Montage muss das Produkt auf Transportschäden untersucht werden. Nach dem Einbau werden keine Transport- oder Oberflächenschäden anerkannt.
- Die Leitungen und die Armatur müssen nach den gültigen Normen montiert, gespült und geprüft werden.
- Die in den Ländern jeweils gültigen Installationsrichtlinien sind einzuhalten.

Technische Daten

Armatur serienmäßig mit EcoSmart® (Durchflussbegrenzer)

Betriebsdruck: max. 1 MPa

Empfohlene Heißwassertemperatur: 0,1 - 0,5 MPa

Prüfdruck: 1,6 MPa

(1 MPa = 10 bar = 147 PSI)

Das Produkt ist ausschließlich für Trinkwasser konzipiert!

Symbolklärung



Kein essigsäurehaltiges Silikon verwenden!



Maße (siehe Seite 18)



Durchflussdiagramm
(siehe Seite 18)



Prüfzeichen (siehe Seite 20)



Serviceteile

(siehe Seite 19)

XXX = Farbcodierung

000 = chrom

820 = brushed nickel

930 = Polished Brass



Reinigung

siehe beiliegende Broschüre



Bedienung (siehe Seite 20)

Montage

siehe Seite 17

Consignes de sécurité

- Lors du montage, porter des gants de protection pour éviter toute blessure par écrasement ou coupure.
- Le produit ne doit servir qu'à se laver et à assurer l'hygiène corporelle.

Instructions pour le montage

- Avant son montage, s'assurer que le produit n'a subi aucun dommage pendant le transport. Après le montage, tout dommage de transport ou de surface ne pourra pas être reconnu.
- Les conduites et la robinetterie doivent être montés, rincés et contrôlés selon les normes en vigueur.
- Les directives d'installation en vigueur dans le pays concerné doivent être respectées.

Informations techniques

Robinetterie équipée en série d'un EcoSmart®
(limiteur de débit)

Pression de service autorisée: max. 1 MPa

Température recommandée: 0,1 - 0,5 MPa

Pression maximum de contrôle: 1,6 MPa

(1 MPa = 10 bar = 147 PSI)

Le produit est exclusivement conçu pour de l'eau potable!

Description du symbole



Ne pas utiliser de silicone contenant de l'acide acétique!



Dimensions (voir pages 18)



Diagramme du débit
(voir pages 18)



Classification acoustique et débit (voir pages 20)



Pièces détachées

(voir pages 19)

XXX = Couleurs

000 = chromé

820 = brushed nickel

930 = Polished Brass



Nettoyage

voir la brochure ci-jointe



Instructions de service (voir pages 20)

Montage

voir pages 17





⚠ Safety Notes

- ⚠ Gloves should be worn during installation to prevent crushing and cutting injuries.
- ⚠ The product may only be used for bathing, hygienic and body cleaning purposes.

Installation Instructions

- Prior to installation, inspect the product for transport damages. After it has been installed, no transport or surface damage will be honoured.
- The pipes and the fixture must be installed, flushed and tested as per the applicable standards.
- The plumbing codes applicable in the respective countries must be observed.

Technical Data

This mixer series-produced with EcoSmart® (flow limiter)

Operating pressure: max. 1 MPa

Recommended hot water temp.: 0,1 - 0,5 MPa

Test pressure: 1,6 MPa

(1 MPa = 10 bar = 147 PSI)

The product is exclusively designed for drinking water!

Symbol description



Do not use silicone containing acetic acid!



Dimensions (see page 18)



Flow diagram

(see page 18)



Test certificate (see page 20)



Spare parts

(see page 19)

XXX = Colors

000 = chrome plated

820 = brushed nickel

930 = Polished Brass



Cleaning

see enclosed brochure



Operation (see page 20)

Assembly
see page 17



⚠ Indicazioni sulla sicurezza

- ⚠ Durante il montaggio, per evitare ferite da schiacciamento e da taglio bisogna indossare guanti protettivi.
- ⚠ Il prodotto deve essere utilizzato esclusivamente per fare il bagno e per l'igiene del corpo.

Istruzioni per il montaggio

- Prima del montaggio è necessario controllare che non ci siano stati danni durante il trasporto. Una volta eseguito il montaggio, non verranno riconosciuti eventuali danni di trasporto o delle superfici.
- Montare, lavare e controllare tubature e rubinetteria rispettando le norme correnti.
- Vanno rispettate le direttive di installazione nazionali vigenti nel rispettivo paese.

Dati tecnici

Questo miscelatore è dotato di serie del Eco-Smart® (limitatore di flusso)

Pressione d'uso: max. 1 MPa

Temp. dell'acqua calda consigliata: 0,1 - 0,5 MPa

Pressione di prova: 1,6 MPa

(1 MPa = 10 bar = 147 PSI)

Il prodotto è concepito esclusivamente per acqua potabile!

Descrizione simbolo



Non utilizzare silicone contenente acido acetico!



Ingombri (vedi pagg. 18)



Diagramma flusso

(vedi pagg. 18)



Segno di verifica (vedi pagg. 20)



Parti di ricambio

(vedi pagg. 19)

XXX = Trattamento

000 = cromato

820 = brushed nickel

930 = Polished Brass



Pulitura

vedi il prospetto accluso



Procedura (vedi pagg. 20)

Montaggio
vedi pagg. 17



⚠ Indicaciones de seguridad

- ⚠ Durante el montaje deben utilizarse guantes para evitar heridas por aplastamiento o corte.
- ⚠ El producto solo debe ser utilizado para fines de baño, higiene y limpieza corporal.

Indicaciones para el montaje

- Antes del montaje se debe examinarse el producto contra daños de transporte. Después de la instalación no se reconoce ningún daño de transporte o de superficie.
- Los conductos y la grifería deben montarse, lavarse y comprobarse según las normas vigentes.
- Es obligatorio el cumplimiento de las directrices de instalación vigentes en el país respectivo.

Datos técnicos

Grifo, desde fábrica equipado con EcoSmart®

(limitador de caudal)

Presión en servicio: max. 1 MPa

Temp. recomendada del agua caliente: 0,1 - 0,5 MPa

Presión de prueba: 1,6 MPa

(1 MPa = 10 bar = 147 PSI)

El producto ha sido concebido exclusivamente para agua potable.

Descripción de símbolos



No utilizar silicona que contiene ácido acético!



Dimensiones (ver página 18)



Diagrama de circulación
(ver página 18)



Marca de verificación (ver página 20)



Repuestos

(ver página 19)

XXX = Acabados

000 = cromado

820 = brushed nickel

930 = Polished Brass



Limpiar

ver el folleto adjunto



Manejo (ver página 20)

⚠ Veiligheidsinstructies

- ⚠ Bij de montage moeten ter voorkoming van kniel- en snijwonden handschoenen worden gedragen.
- ⚠ Het product mag alleen voor het wassen, hygiënische doeleinden en voor de lichaamreiniging worden gebruikt.

Montage-instructies

- Vóór de montage moet het product gecontroleerd worden op transportschade. Na de inbouw wordt geen transport- of oppervlakteschade meer aanvaard.
- De leidingen en armaturen moeten gemonteerd, gespoid en gecontroleerd worden volgens de geldige normen.
- De in de overeenkomstige landen geldende installatierichtlijnen moeten nageleefd worden.

Technische gegevens

Armatuur standaard met EcoSmart® (doorstroombegrenzer)

Werkdruk: max.

max. 1 MPa

Aanbevolen warm water temp.:

0,1 - 0,5 MPa

Getest bij:

1,6 MPa

(1 MPa = 10 bar = 147 PSI)

Het product is uitsluitend ontworpen voor drinkwater!

Symboolbeschrijving



Gebruik geen zuurhoudende silicone!



Maten (zie blz. 18)



Doorstroomdiagram
(zie blz. 18)



Keurmerk (zie blz. 20)



Service onderdelen

(zie blz. 19)

XXX = Kleuren

000 = verchromd

820 = brushed nickel

930 = Polished Brass



Reinigen

zie bijgevoegde brochure



Bediening (zie blz. 20)



Montaje



ver página 17

Montage

zie blz. 17



Sikkerhedsanvisninger

-  Ved monteringen skal der bruges handsker for at undgå kvæstelser og snitsår.
-  Produktet må kun bruges til bade-, hygiejne og kropsrengøringsformål.

Monteringsanvisninger

- Før monteringen skal produktet kontrolleres for transportskader. Efter monteringen godkendes transportskader eller skader på overfladen ikke længere.
- Ledningerne og armaturerne skal monteres, skylles og kontrolleres iht. de gældende standarder.
- Installationsbestemmelserne, der gælder i det enkelte land, skal overholdes.

Tekniske data

Armaturet er forsynet med EcoSmart® (gennemstrømningsbegrænser)

Driftstryk:	max. 1 MPa
Anbefalet varmtvandstemperatur:	0,1 - 0,5 MPa
Prøvetryk:	1,6 MPa
(1 MPa = 10 bar = 147 PSI)	
Produktet er udelukkende beregnet til drikkevand!	

Symbolbeskrivelse



Der må ikke benyttes eddikesyreholdig silikone!



Målene (se s. 18)



Gennemstrømningsdiagram
(se s. 18)



Godkendelse (se s. 20)



Reserve dele

(se s. 19)

XXX = Overflade

000 = Krom

820 = Brushed nickel

930 = Polished Brass



Rengøring



se venligst den vedlagte brochure



Brugsanvisning (se s. 20)

Montering
se s. 17

Avisos de segurança

-  Durante a montagem devem ser utilizadas luvas de protecção, de modo a evitar ferimentos resultantes de entalamentos e de cortes.
-  O produto só pode ser utilizado para fins de higiene pessoal.

Avisos de montagem

- Antes da montagem deve-se controlar o produto relativamente a danos de transporte. Após a montagem não são aceites quaisquer danos de transporte ou de superfície.
- As tubagens e a torneira têm que ser montadas, enxaguadas e verificadas de acordo com as normas em vigor.
- A prescrições de instalação válidas nos respetivos países devem ser respeitadas.

Dados Técnicos

Misturadoras produzidas em série com EcoSmart® (limitador de caudal)

Pressão de funcionamento:	max. 1 MPa
Temp. água quente recomendada:	0,1 - 0,5 MPa
Pressão testada:	1,6 MPa
(1 MPa = 10 bar = 147 PSI)	

Este produto foi única e exclusivamente concebido para água potável!

Descrição do símbolo



Não utilizar silicone que contenha ácido acético!



Medidas (ver página 18)



Fluxograma
(ver página 18)



Marca de controlo (ver página 20)



Peças de substituição

(ver página 19)

XXX = Acabamentos

000 = cromado

820 = brushed nickel

930 = Polished Brass



Limpeza

consultar a seguinte brochura



Funcionamento (ver página 20)

Montagem
ver página 17



**! Wskazówki bezpieczeństwa**

- △ Aby uniknąć zranień na skutek zgniecenia lub przecięcia, podczas montażu należy nosić rękawice ochronne.
- △ Produkt może być używany tylko do kąpieli, higieny i czyszczenia ciała.

Wskazówki montażowe

- Przed montażem należy skontrolować produkt pod kątem szkód transportowych. Po montażu nie widać żadnych szkód transportowych ani szkód na powierzchni.
- Przewody i armatura muszą być montowane, płukane i kontrolowane według obowiązujących norm.
- Należy przestrzegać wytycznych instalacyjnych obowiązujących w danym kraju.

Dane techniczne**Armatura produkowana seryjnie z funkcją****EcoSmart®** (ogranicznik przepływu)

Ciśnienie robocze: maks. 1 MPa

Zalecana temperatura wody gorącej: 0,1 - 0,5 MPa

Ciśnienie próbne: 1,6 MPa

(1 MPa = 10 bary = 147 PSI)

Produkt przeznaczony wyłącznie do wody pitnej!

! Bezpečnostní pokyny

- △ Pro zabránění řezným zraněním a pohmožděním je nutné při montáži nosit rukavice.
- △ Produkt smí být používán pouze ke koupání a za účelem tělesné hygieny.

Pokyny k montáži

- Před montáží je třeba produkt zkontrolovat, zda nebyl při transportu poškozen. Po zabudování nebudou uznány žádné škody způsobené transportem nebo poškození povrchu.
- Vedení a armatura musí být namontovány, propláchnuty a otestovány podle platných norem.
- Je třeba dodržovat montážní pravidla platné v dané zemi.

Technické údaje**Armatura je sériově vybavena zařízením****EcoSmart®** (omezovač průtoku)

Provozní tlak: max. 1 MPa

Doporučená teplota horké vody: 0,1 - 0,5 MPa

Zkušební tlak: 1,6 MPa

(1 MPa = 10 bar = 147 PSI)

Výrobky Hansgrohe jsou vhodné pro přímý kontakt s pitnou vodou.

Opis symbolu

Nie stosować silikonów zawierających kwas octowy!

**Wymiary** (patrz strona 18)**Schemat przepływu**

(patrz strona 18)

**Znak jakości** (patrz strona 20)**Części serwisowe**

(patrz strona 19)

XXX = Kody kolorów

000 = chrom

820 = nikiel szorowany

930 = Polished Brass

**Czyszczenie**

patrz dołączona broszura

**Obsługa** (patrz strona 20)**Popis symbolů**

Nepoužívat silikon s obsahem kyseliny octové!

**Rozměry** (viz strana 18)**Diagram průtoku**

(viz strana 18)

**Zkušební značka** (viz strana 20)**Servisní díly**

(viz strana 19)

XXX = Kód povrchové úpravy

000 = chrom

820 = brushed nickel

930 = Polished Brass

**Čištění**

viz přiložená brožura

**Ovládání** (viz strana 20)**Montaż****patrz strona 17****Montáž****viz strana 17**



⚠ Bezpečnostné pokyny

- ⚠ Pri montáži musíte nosiť rukavice, aby ste predišli pomliaždeninám a rezným poraneniam.
- ⚠ Produkt sa smie používať len na kúpanie a telesnú hygienu.

Pokyny pre montáž

- Pred montážou musíte produkt skontrolovať, či nebol počas transportu poškodený. Po zabudovaní nebudú uznané žiadne škody spôsobené transportom alebo poškodenia povrchu.
- Ledningarna och blandaren måste monteras, spolagsigenom och kontrolleras enligt de gällande normerna.
- Je potrebné dodržiavať smernice o inštalácii, ktoré sú práve teraz platné v krajinách.

Technické údaje

Armatúra je sériovo vybavená zariadením

EcoSmart® (obmedzovač prietoku)

Prevádzkový tlak: max. 1 MPa

Doporučená teplota teplej vody: 0,1 - 0,5 MPa

Skúšobný tlak: 1,6 MPa

(1 MPa = 10 bar = 147 PSI)

Výrobok je koncipovaný výhradne pre pitnú vodu!

⚠ 安全技巧

- ⚠ 装配时为避免挤压和切割受伤，必须戴上手套。
- ⚠ 本产品只允许作为洗浴、卫生和洁身之用。

安装提示

- 安装前必须检查产品是否受到运输损害。安装后将不认可运输损害或表面损伤。
- 管道和阀门必须根据通用标准进行安装、冲洗和检查。
- 请遵守当地国家现行的安装规定。

技术参数

本龙头配有 **EcoSmart®** (流量限制器)

工作压力: 最大 1 MPa

推荐热水温度: 0,1 - 0,5 MPa

测试压强: 1,6 MPa

(1 MPa = 10 bar = 147 PSI)

该产品专为饮用水设计!

Popis symbolov



Nepoužívať silikón s obsahom kyseliny octovej!



Rozmery (viď strana 18)



Diagram prietoku

(viď strana 18)



Osvedčenie o skúške (viď strana 20)



Servisné diely

(viď strana 19)

XXX = Farebné označenie

000 = chróm

820 = brushed nickel

930 = Polished Brass



Čistenie

nájdate v priloženej brožúre



Obsluha (viď strana 20)

符号说明



请勿使用含有乙酸的硅胶!



大小 (参见第页 18)



流量示意图

(参见第页 18)



检验标记 (参见第页 20)



备用零件

(参见第页 19)

XXX = 颜色代码

000 = 镀铬

820 = 镍拉丝

930 = Polished Brass



清洗

附有小手册



操作 (参见第页 20)

Montáž

viď strana 17



安装

参见第页 17

**⚠ Указания по технике безопасности**

- ⚠ Во время монтажа следует надеть перчатки во избежание прищемления и порезов.
- ⚠ Изделие разрешается использовать только в гигиенических целях: для принятия ванны и личной гигиены.

Указания по монтажу

- Перед монтажом следует проверить изделие на предмет повреждений при перевозке. После монтажа претензии о возмещении ущерба за повреждения при перевозке или повреждения поверхностей не принимаются.
- Трубы и арматура должны быть установлены, промыты и проверены в соответствии с действующими нормами.
- Необходимо соблюдать требования по монтажу, действующие в соответствующих странах.

Технические данные**Смесители этой серии серийно оснащаются****EcoSmart®** (ограничителем потока воды)

Рабочее давление: не более 1 МПа

Рекомендуемая темп. гор. воды: 0,1 - 0,5 МПа

Давление: 1,6 МПа

(1 МПа = 10 bar = 147 PSI)

Изделие предназначено исключительно для питьевой воды!

Описание символов

Не применяйте силикон, содержащий уксусную кислоту.

**Размеры** (см. стр. 18)**Схема потока**

(см. стр. 18)

**Знак технического контроля**

(см. стр. 20)

**Комплект**

(см. стр. 19)

XXX = Цветная кодировка

000 = хром

820 = brushed nickel

930 = Polished Brass

**Очистка**

см прилагаемая брошюра

**Эксплуатация** (см. стр. 20)**Монтаж**

см. стр. 17

⚠ Biztonsági utasítások

- ⚠ A szerelésnél a zúzódások és vágási sérülések elkerülése érdekében kesztyűt kell viselni.
- ⚠ A terméket csak fürdéshez, mosakodáshoz, és egészségügyi tisztálkodáshoz szabad használni.

Szerelési utasítások

- A szerelés előtt ellenőrizni kell, hogy a terméknek nincs-e szállítási sérülése. Beépítés után a szállítási vagy felületi sérüléseket nem ismerik el.
- A vezetékeket és a csaptelepet az érvényes szabványoknak megfelelően kell felszerelni, öblíteni és ellenőrizni
- Az egyes országokban érvényes installációs irányelveket be kell tartani.

Műszaki adatok**A csaptelep szériakivitelben el van látva EcoSmart® (átfolyáskorlátozó) berendezéssel**

Üzemi nyomás: max. 1 МПа

Forróvíz javasolt hőmérséklete: 0,1 - 0,5 МПа

Nyomáspróba: 1,6 МПа

(1 МПа = 10 bar = 147 PSI)

A terméket kizárólag ivóvízhez tervezték!

Szimbólumok leírása

Ne használjon ecetsavtartalmú szilikon!

**Méretet** (lásd a oldalon 18)**Átfolyási diagramm**

(lásd a oldalon 18)

**Vizsgajel** (lásd a oldalon 20)**Tartozékok**

(lásd a oldalon 19)

XXX = Színekódolás

000 = króm

820 = brushed nickel

930 = Polished Brass

**Tisztítás**

lásd a mellékelt brosúrát

**Használat** (lásd a oldalon 20)**Szerelés**

lásd a oldalon 17





⚠ Turvallisuusohjeet

- △ Asennuksessa on käytettävä käsineitä puristumien ja viltojen aiheuttamien tapaturmien estämiseksi.
- △ Tuotetta saa käyttää ainoastaan kylpy-, hygienia- ja puhdistustarkoituksiin.

Asennusohjeet

- Ennen asennusta on tarkastettava tuotteen mahdolliset kuljetusvahingot. Asennuksen jälkeen kuljetus- ja pintavaurioita ei hyväksytä.
- Putket ja hana on asennettava, huuhdeltava ja tarkastettava voimassa olevien standardien mukaisesti.
- Jokaisessa maassa on noudatettava siellä päteviä asennusohjeita.

Tekniset tiedot

Kaluste on vakiona varustettu EcoSmart® (virtauksenrajoittimella)

Käyttöpaine:	maks. 1 MPa
Kuuman veden suosituslämpötila:	0,1 - 0,5 MPa
Koestuspaine:	1,6 MPa
(1 MPa = 10 bar = 147 PSI)	

Tuote on suunniteltu käytettäväksi ainoastaan juomaveden kanssa!

Merkin kuvaus



Älä käytä etikkahappopitoista silikonia!



Mitat (katso sivu 18)



Virtausdiagrammi
(katso sivu 18)



Koestusmerkki (katso sivu 20)



Varaosat

(katso sivu 19)

XXX = Värikoodaus

000 = kromi

820 = harjattu nikkeli

930 = Polished Brass



Puhdistus

katso oheinen esite



Käyttö (katso sivu 20)

⚠ Säkerhetsanvisningar

- △ Handskar ska bäras under monteringsarbetet så att man kan undvika kläm- och skärskadorgen werden.
- △ Produkten får bara användas till kroppshygien med bad och dusch.

Monteringsanvisningar

- Det måste undersökas om produkten har transportskador innan den monteras. Efter monteringen accepteras inga transport- eller ytskiktsskador.
- Ledningarna och blandaren måste monteras, spolats igenom och kontrolleras enligt de gällande normerna.
- De installationsriktlinjer som gäller i länderna ska följas.

Tekniska data

Blandare seriemässigt med EcoSmart® (flödeskontroll)

Driftstryck:	maks. 1 MPa
Rek. varmvattentemp.:	0,1 - 0,5 MPa
Tryck vid provtryckning:	1,6 MPa
(1 MPa = 10 bar = 147 PSI)	

Produkten är enbart avsedd för dricksvatten!

Symbolförklaring



Använd inte silikon som innehåller ättiksyra!



Måtten (se sidan 18)



Flödesschema
(se sidan 18)



Testsigill (se sidan 20)



Reservdelar

(se sidan 19)

XXX = Färgkodning

000 = krom

820 = borstad nickel

930 = Polished Brass



Rengöring

se den medföljande broschyren



Hantering (se sidan 20)

Asennus
katso sivu 17



Montering
se sidan 17



Saugumo technikos nurodymai

- △ Apsaugai nuo užspaudimo ir įsijovimo montavimo metu mūvėkite pirštines.
- △ Gaminys turi būti naudojamas tik maudymuisi, kūno higienai ir švarai palaikyti.

Montavimo instrukcija

- Prieš montuojant būtina patikrinti, ar gaminys nebuvo pažeistas transportavimo metu. Sumontavus pretenzijos dėl transportavimo ir paviršiaus pažeidimų nepriimamos.
- Vamzdžiai ir sujungimai turi būti montuojami, plaunami ir tikrinami pagal galiojančias normas.
- Laikykitės atitinkamoje šalyje galiojančių direktyvų dėl įrengimo.

Techniniai duomenys

Šios serijos maišytuvai turi EcoSmart® (vandens srauto ribotuvą)

Darbinis slėgis: ne daugiau kaip 1 MPa
Rekomenduojama karšto vandens temperatūra: 0,1 - 0,5 MPa

Bandomasis slėgis: 1,6 MPa
(1 MPa = 10 barų = 147 PSI)

Produktas skirtas tik geriamajam vandeniui!

Sigurnosne upute

- △ Prilikom montaže se radi sprječavanja prignječjenja i posjekotina moraju nositi rukavice.
- △ Proizvod se smije primjenjivati samo za kupanje, tuširanje i osobnu higijenu.

Upute za montažu

- Prije montaže mora se provjeriti je li proizvod oštećen prilikom transporta. Nakon ugradnje se ne priznaju nikakve reklamacije koje se odnose na površinska i transportna oštećenja.
- Cijevi i armatura moraju biti postavljeni, isprani i testirani prema važećim normama.
- Obvezno se moraju uvažiti propisi o instalacijama koji vrijede u dotičnoj zemlji.

Tehnički podatci

Armatura ima serijski ugrađen EcoSmart® (limitator protoka)

Najveći dopušteni tlak: tlak 1 MPa

Preporučena temperatura vruće vode: 0,1 - 0,5 MPa

Probni tlak: 1,6 MPa

(1 MPa = 10 bar = 147 PSI)

Proizvod je koncipiran isključivo za pitku vodu!

Simbolio aprašymas



Nenaudokite silikono, kurio sudėtyje yra acto rūgšties!



Išmatavimai (žr. psl. 18)



Pralaidumo diagrama
(žr. psl. 18)



Bandymo pažyma (žr. psl. 20)



Atsarginės dalys

(žr. psl. 19)

XXX = Spalvos

000 = chrom

820 = brushed nickel

930 = Polished Brass

Opis simbola



Nemojte koristiti silikon koji sadrži octenu kiselinu!



Mjere (pogledaj stranicu 18)



Dijagram protoka
(pogledaj stranicu 18)



Oznaka testiranja (pogledaj stranicu 20)



Rezervni djelovi

(pogledaj stranicu 19)

XXX = Boje

000 = krom

820 = brushed nickel

930 = Polished Brass



Valymas

žr. pridedamoje brošiūroje



Eksplotacija (žr. psl. 20)



Čišćenje

se u priloženoj brošiuri



Upotreba (pogledaj stranicu 20)

Montavimas

žr. psl. 17



Sastavljanje

pogledaj stranicu 17



⚠ Güvenlik uyarıları

- ⚠ Montaj esnasında ezilme ve kesilme gibi yaralanmaları önlemek için eldiven kullanılmalıdır.
- ⚠ Ürün yalnızca banyo, hijyen ve beden temizliği amaçları doğrultusunda kullanılabilir.

Montaj açıklamaları

- Montaj işleminden önce ürün nakliye hasarları yönünden kontrol edilmelidir. Montaj işleminden sonra nakliye veya yüzey hasarları için sorumluluk üstlenilmemektedir.
- Boruların ve armatürün montajı, yıkanması ve kontrolü geçerli normlara göre yapılmalıdır.
- Ülkelerde geçerli kurulum yönetmeliklerine riayet edilmelidir.

Teknik bilgiler

Batarya EcoSmart® (akış sınırlayıcısı) ile birlikte seri olarak

İşletme basıncı:	azami 1 MPa
Tavsiye edilen su ısısı:	0,1 - 0,5 MPa
Kontrol basıncı:	1,6 MPa

(1 MPa = 10 bar = 147 PSI)
Ürün sadece şebeke suyu için tasarlanmıştır!

⚠ Instrucțiuni de siguranță

- ⚠ La montare utilizați mânăși pentru evitarea contuziunilor și tăierii mâinilor.
- ⚠ Produsul poate fi utilizat doar pentru spălarea, menținerea igienei și curățarea corpului.

Instrucțiuni de montare

- Înainte de instalare verificați, dacă produsul prezintă deteriorări de transport. După instalare garanția nu acoperă deteriorările de transport și cele de suprafață.
- Conductele și bateriile trebuie montate, spălate și verificate conform normelor în vigoare.
- Respectați reglementările referitoare la instalare valabile în țara respectivă.

Date tehnice

Bateria este dotată în serie cu EcoSmart® (limitator de debit)

Presiune de funcționare:	max. 1 MPa
Temperatura recomandată a apei calde:	0,1 - 0,5 MPa
Presiune de verificare:	1,6 MPa

(1 MPa = 10 bar = 147 PSI)
Produsul este destinat exclusiv pentru apă potabilă.

Simge açıklaması



Asetik asit içeren silikon kullanmayın!



Ölçüleri (bakınız sayfa 18)



Akış diyagramı
(bakınız sayfa 18)



Kontrol işareti (bakınız sayfa 20)



Yedek Parçalar
(bakınız sayfa 19)

XXX = Renkler
000 = krom
820 = brushed nickel
930 = Polished Brass



Temizleme

birlikte verilen broşür



Kullanımı (bakınız sayfa 20)

Descrierea simbolurilor



Nu utilizați silicon cu conținut de acid acetic!



Dimensiuni (vezi pag. 18)



Diagrama de debit
(vezi pag. 18)



Certificat de testare (vezi pag. 20)



Piese de schimb
(vezi pag. 19)

XXX = Coduri de culori
000 = crom
820 = nichel mat
930 = Polished Brass



Curățare

vezi broșura alăturată



Utilizare (vezi pag. 20)

Montajı
bakınız sayfa 17



Montare
vezi pag. 17

**⚠ Υποδείξεις ασφαλείας**

- ⚠ Για να αποφύγετε τραυματισμούς κατά τη συναρμολόγηση πρέπει να φοράτε γάντια.
- ⚠ Το προϊόν επιτρέπεται να χρησιμοποιείται μόνο σαν μέσο λουτρού, υγιεινής και καθαρισμού του σώματος.

Οδηγίες συναρμολόγησης

- Πριν τη συναρμολόγηση πρέπει να εξεταστεί το προϊόν για ζημιές μεταφοράς. Μετά την εγκατάσταση δεν αναγνωρίζονται ζημιές από τη μεταφορά ή επιφανειακές ζημιές.
- Οι σωλήνες και η μπαταρία πρέπει να τοποθετηθούν σύμφωνα με τα ισχύοντα πρότυπα, να τεθούν υπό πίεση και να δοκιμαστούν.
- Θα πρέπει να τηρούνται οι οδηγίες εγκατάστασης που ισχύουν σε κάθε κράτος.

Τεχνικά Χαρακτηριστικά**Μπαταρία νόμιμα εξοπλισμένη με EcoSmart®**

(μειωτής ροής)

Λειτουργία πίεσης:

έως 1 MPa

Συνιστώμενη θερμοκρασία ζεστού νερού: 0,1 - 0,5 MPa

Πίεση ελέγχου:

1,6 MPa

(1 MPa = 10 bar = 147 PSI)

Το προϊόν έχει σχεδιαστεί αποκλειστικά για πόσιμο νερό!

Περιγραφή συμβόλων

Μην χρησιμοποιείτε σιλικόνη που περιέχει οξικό οξύ!

**Διαστάσεις** (βλ. Σελίδα 18)**Διάγραμμα ροής**

(βλ. Σελίδα 18)

**Σήμα ελέγχου** (βλ. Σελίδα 20)**Ανταλλακτικά**

(βλ. Σελίδα 19)

XXX = Χρώματα

000 = Επιχρωμιωμένο

820 = νικελ ματ

930 = Polished Brass

**Καθαρισμός**

βλ. συνημμένο φυλλάδιο

**Χειρισμός** (βλ. Σελίδα 20)**Συναρμολόγηση**
βλ. Σελίδα 17**⚠ Varnostna opozorila**

- ⚠ Pri montaži je treba nositi rokavice, da se preprečijo poškodbe zaradi zmečkanja ali urezov.
- ⚠ Ta izdelek se sme uporabljati le z namenom umivanja, vzdrževanja higijene in telesne nege.

Navodila za montažo

- Pred montažo je treba izdelek preveriti glede morebitnih transportnih poškodb. Po vgradnji transportne ali površinske poškodbe ne bodo več priznane.
- Cevi in armaturo je treba montirati, izprati in preveriti po veljavnih standardih.
- Upoštevati je treba pravilnike o inštalacijah, ki veljajo v posamezni državi.

Tehnični podatki**Armaturo je serijsko opremljena z EcoSmart®**

(omejevalnikom pretoka)

Delovni tlak:

maks. 1 MPa

Priporočena temperatura tople vode:

0,1 - 0,5 MPa

Preskusni tlak:

1,6 MPa

(1 MPa = 10 bar = 147 PSI)

Proizvod je zasnovan izključno za sanitarno vodo!

Opis simbola

Ne smete uporabiti silikona, ki vsebuje očetno kislino!

**Mere** (glejte stran 18)**Diagram pretoka**

(glejte stran 18)

**Preskusni znak** (glejte stran 20)**Rezervni deli**

(glejte stran 19)

XXX = Barve

000 = krom

820 = brushed nickel

930 = Polished Brass

**Čiščenje**

glejte priloženi brošuri

**Upravljanje** (glejte stran 20)**Montaža**
glejte stran 17



⚠ Ohutusjuhised

- △ Kandke paigaldamisel muljumis- ja löikevigastuste vältimiseks kindaid.
- △ Toodet tohib kasutada ainult pesemis-, hügieeni- ja kehahupastamiseesmärkidel.

Paigaldamisjuhised

- Enne paigaldamist tuleb toodet kontrollida transportdihajustuste osas Pärast paigaldamist ei tunnustata enam transporti- või pinnakahjustuste kaebuseid.
- Voolikute ja segisti paigaldamisel, loputamisel ja kontrollimisel tuleb lähtuda kehtivatest normatiividest
- Vastavas riigis kehtivaid paigalduseeskirju tuleb järgida.

Tehnilised andmed

Segistisari on toodetud koos EcoSmart® (veehulgaipiirajaga)

Töörõhk maks. 1 MPa
 Soovitatav kuuma vee temperatuur: 0,1 - 0,5 MPa
 Kontrollsurve: 1,6 MPa
 (1 MPa = 10 baari = 147 PSI)

Toode on ette nähtud eranditult joogivee jaoks!

⚠ Drošības norādes

- △ Montāžas laikā, lai izvairītos no saspiedumiem un iegriezumiem, nepieciešams nēsāt cimdus.
- △ Šo produktu drīkst izmantot tikai, lai mazgātos, higiēnai un ķermeņa tīrīšanai.

Norādījumi montāžai

- Pirms montāžas nepieciešams pārbaudīt, vai produktam transportēšanas laikā nav radušies bojājumi. Pēc iebūvēšanas bojājumi, kas radušies transportēšanas laikā, vai virsmas bojājumi netiek atzīti.
- Caurplūvadi un armatūra ir jāuzstāda, jāizskalo un jāpārbauda saskaņā ar spēkā esošajiem standartiem.
- Jāievēro attiecīgās valsts spēkā esošās montāžas prasības.

Tehniskie dati

Jaucējkrāns tiek ražots kopā ar EcoSmart®

(caurteces ierobežotāju)

Darba spiediens: maks. 1 MPa
 Ieteicamā karstā ūdens temperatūra: 0,1 - 0,5 MPa
 Pārbaudes spiediens: 1,6 MPa
 (1 MPa = 10 bar = 147 PSI)

Izstrādājums ir paredzēts tikai dzeramajam ūdenim!

Sūmbolite kirjeldus



Ärge kasutage äädikhapet sisaldavat silikooni!



Mõõtude (vt lk 18)



Läbivooludiagramm
(vt lk 18)



Kontrollsertifikaat (vt lk 20)



Varuosad

(vt lk 19)

XXX = Värvid

000 = kroom

820 = brushed nickel

930 = Polished Brass

Symbolu nozīme



Neizmantot silikonu, kas satur etiķskābi!



Izmērus (skat. lpp. 18)



Caurplūdes diagramma
(skat. lpp. 18)



Pārbaudes zīme (skat. lpp. 20)



Rezerves daļas

(skat. lpp. 19)

XXX = Krāsu kodi

000 = hroma

820 = brushed nickel

930 = Polished Brass



Puhastamine

vt kaasasolevast brošūrist



Kasutamine (vt lk 20)



Tīrīšana

skatiet pievienotajā brošūrā



Lietošana (skat. lpp. 20)

Paigaldamine
vt lk 17



Montāža
skat. lpp. 17



Sigurnosne napomene

- Prilikom montaže se radi sprečavanja prignječenja i posekotina moraju nositi rukavice.
- Proizvod sme da se koristi samo za kupanje, tuširanje i ličnu higijenu.

Instrukcije za montažu

- Pre montaže se mora proveriti da li je proizvod oštećen pri transportu. Nakon ugradnje se ne priznaju nikakve reklamacije koje se odnose na površinska i transportna oštećenja.
- Vodovi i armatura moraju biti postavljeni, isprani i testirani prema važećim normama.
- Treba se pridržavati propisa koji u određenim zemljama važe za instalacije.

Tehnički podaci

Ove armature imaju serijski ugrađen

EcoSmart® (ograničavač protoka vode)

Radni pritisak: maks. 1 MPa

Preporučena temperatura vruće vode: 0,1 - 0,5 MPa

Probni pritisak: 1,6 MPa

(1 MPa = 10 bar = 147 PSI)

Proizvod je koncipiran isključivo za pijaću vodu!

Sikkerhetshenvisninger

- Bruk hansker under montasjen for å unngå klem- og kuttskader.
- Produktet skal kun brukes for bade-, hygiene- og kroppshygiene.

Montagehenvisninger

- Før montasjen skal produktet sjekkes for transportskader. Etter monteringen aksepteres ikke noen transport- eller overflateskader.
- Ledningene og armaturen skal monteres, spyles og sjekkes iht. de gyldige normer.
- Gjeldende retningslinjer for rørleggerarbeid i de enkelte land skal følges.

Tekniske data

Armatur er standardmessig utstyrt med EcoSmart® (gjennomstrømningsbegrenser)

Driftstrykk maks. 1 MPa

Anbefalt temperatur for varmt vann 0,1 - 0,5 MPa

Prøvetrykk 1,6 MPa

(1 MPa = 10 bar = 147 PSI)

Produktet er utelukkende designet for drikkevann!

Opis simbola



Nemojte koristiti silikon koji sadrži sircetnu kiselinu!



Mere (vidi stranu 18)



Dijagram protoka
(vidi stranu 18)



Ispitni znak (vidi stranu 20)



Rezervni delovi
(vidi stranu 19)

XXX = Oznake boja

000 = hrom

820 = brushed nickel

930 = Polished Brass



Čišćenje

vidi priloženoj brošuri



Rukovanje (vidi stranu 20)

Symbolbeskrivelse



Ikke bruk silikon som inneholder eddiksyre!



Mål (se side 18)



Gjennomstrømningsdiagram
(se side 18)



Prøvermerke (se side 20)



Servicelever

(se side 19)

XXX = Fargekode

000 = krom

820 = børstet nikkell

930 = Polished Brass



Rengjøring

se vedlagt brosjyre



Betjening (se side 20)





Указания за безопасност

- При монтажа трябва да се носят ръкавици, за да се избегнат наранявания поради притискане или порязване.
- Позволено е използването на продукта само за къпане, хигиена и цели на почистване на тялото.

Указания за монтаж

- Преди монтажа продуктът трябва да се провери за транспортни щети. След монтажа не се признават транспортни или повърхностни щети.
- Тръбопроводите и арматурата трябва да се монтират, промият и проверят в съответствие с валидните норми.
- Трябва да бъдат спазвани валидните в съответните страни предписания за инсталиране.

Технически данни

Арматурата е оборудвана серийно с

EcoSmart® (ограничител на протичане)

Работно налягане: макс. 1 МПа

Препоръчителна температура на горещата вода:

0,1 - 0,5 МПа

Контролно налягане:

1,6 МПа

(1 МПа = 10 bar = 147 PSI)

Продуктът е разработен само за питейна вода!

Описание на символите



Не използвайте силикон, съдържащ оцетна киселина!



Размери (вижте стр. 18)



Диаграма на потока

(вижте стр. 18)



Контролен знак (вижте стр. 20)



Сервизни части

(вижте стр. 19)

XXX = Цветово кодиране

000 = хром

820 = надраскан никел

930 = Polished Brass



Почистване

от приложената брошура



Обслужване (вижте стр. 20)

Udhëzime sigurie

- Për të evituar lëndime e pickimeve ose të prerjeve gjatë procesit të montimit duhet që të vishni doreza.
- Produkti duhet të përdoret vetëm qëllimet e banjave, të higjienës dhe të larjes së trupit.

Udhëzime për montimin

- Përpara montimit duhet që produkti të kontrollohet për dëmtime nga transporti. Pas instalimit nuk do të njihet asnjë dëmtim nga transporti ose dëmtim i sipërfaqes.
- Tubacionet dhe rubinetet duhet që të montohen, të shpëlahen dhe të kontrollohen sipas standardeve në fuqi
- Duhet të respektohen linjat udhëzuese të instalimit, të vlefshme për vendet respektive.

Të dhëna teknike

Rubineti është i pajisur si standard me

EcoSmart® (Kufizues qarkullimi)

Presioni gjatë punës maks. 1 МПа

Temperatura e rekomanduar e ujit të ngrohtë:

0,1 - 0,5 МПа

Presioni për provë:

1,6 МПа

(1 МПа = 10 bar = 147 PSI)

Produkti është projektuar ekskluzivisht për ujë të pijshëm!

Përshkrimi i simbolit



Mos përdorni silikon që në përbërje ka acid acetik.



Përmasat (shih faqen 18)



Diagrami i qarkullimit

(shih faqen 18)



Shenja e kontrollit (shih faqen 20)



Pjesët e servisit

(shih faqen 19)

XXX = Kodimi me anë të ngjyrave

000 = krom

820 = nikeli i furçuar

930 = Polished Brass



Pastrimi

shikoni broshurën bashkëngjitur



Përdorimi (shih faqen 20)

Монтаж

вижте стр. 17



Montimi

shih faqen 17



⚠️ تنبيهات الأمان

- ⚠️ يجب إرتداء قفازات لليد أثناء التركيب لتجنب حدوث أخطار الإنحشار أو الجروح.
- ⚠️ لا يجب استخدام المنتج إلا في أغراض الاستحمام والأغراض الصحية وأغراض تنظيف الجسم.

تعليمات التركيب

- قبل القيام بعملية التركيب، يجب فحص المنتج للتأكد من خلوه من أية تلفيات ناتجة عن النقل. بعد القيام بعملية التركيب، لن يتم الاعتراف بوجود أية تلفيات سطحية أو تلفيات ناتجة عن عملية النقل.
- يجب تركيب وغسيل واختبار التوصيلات وخلطات المياه طبقاً للمعايير السارية.
- يجب مراعاة القواعد الخاصة بالتركيب وأعمال السباكة وفقاً للوائح الخاصة بكل بلد.

المواصفات الفنية

يتم بشكل قياسي إنتاج الخلاط هذا مع EcoSmart® (محدد تدفق المياه)

- ضغط التشغيل: الحد الأقصى 1 ميجاباسكال
- درجة الحرارة الموصى بها للماء الساخن: 0,1 - 0,5 ميجاباسكال
- ميجاباسكال
- ضغط الاختبار: 1,6 ميجاباسكال
- (1 ميجاباسكال = 10 بار = 147 PSI)
- المنتج مخصص فقط لماء الشرب!

وصف الرمز

هام! لا تستخدم السليكون الذي يحتوي على أمضاض!



أبعاد (راجع صفحة 18)



رسم للصرف

(راجع صفحة 18)



شهادة اختبار (راجع صفحة 20)



قطع الغيار

(راجع صفحة 19)



XXX = الألوان

000 = كروم

820 = نيكيل مفرّش

930 = Polished Brass

التنظيف

راجع والكتيب المرفق



التشغيل (راجع صفحة 20)



التركيب

راجع صفحة 17





Montreux 16530XXX

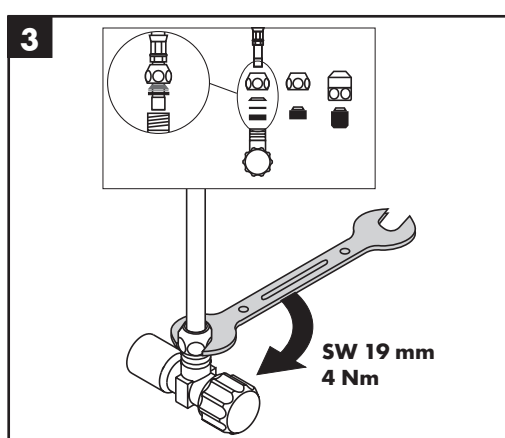
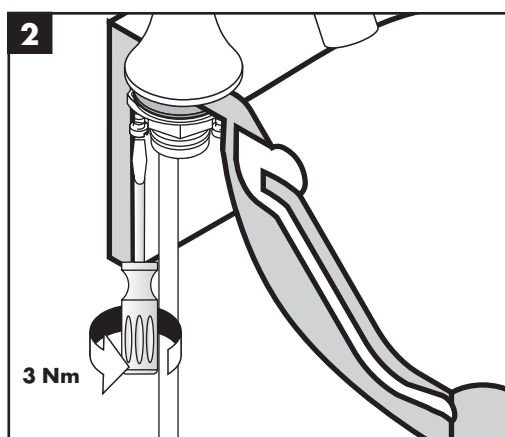
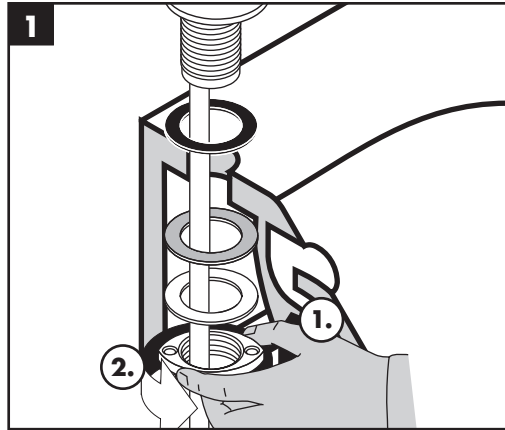

Uno 38130XXX

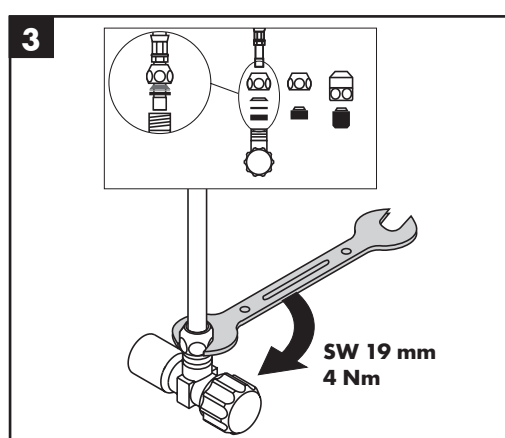
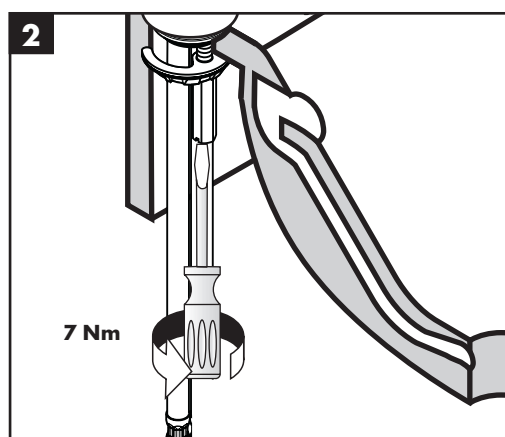
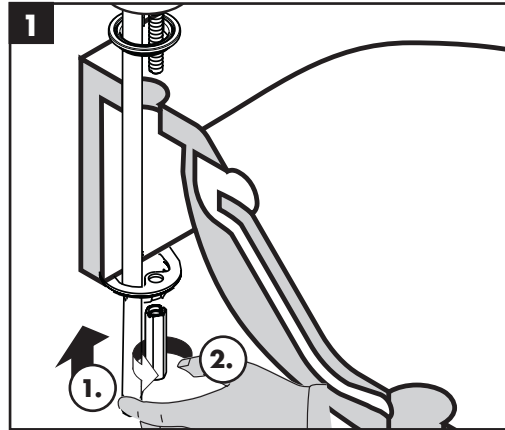



Montreux
16530XXX

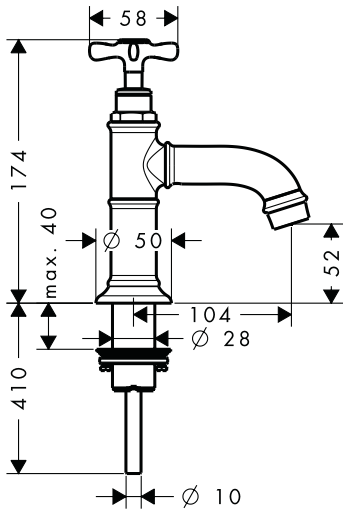

Uno
38130XXX

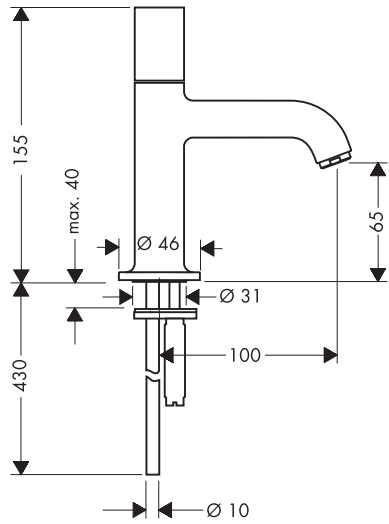

Montreux 16530XXX
Uno 38130XXX

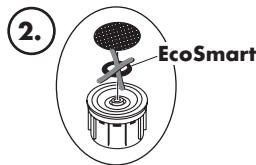
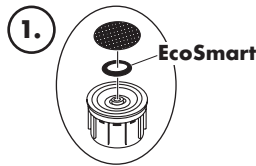
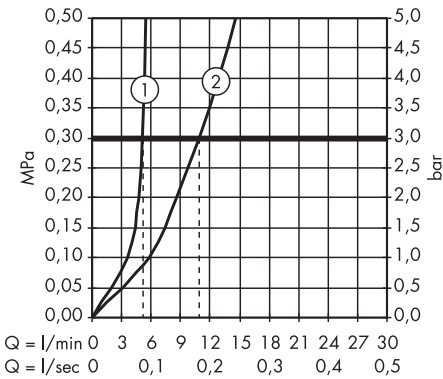

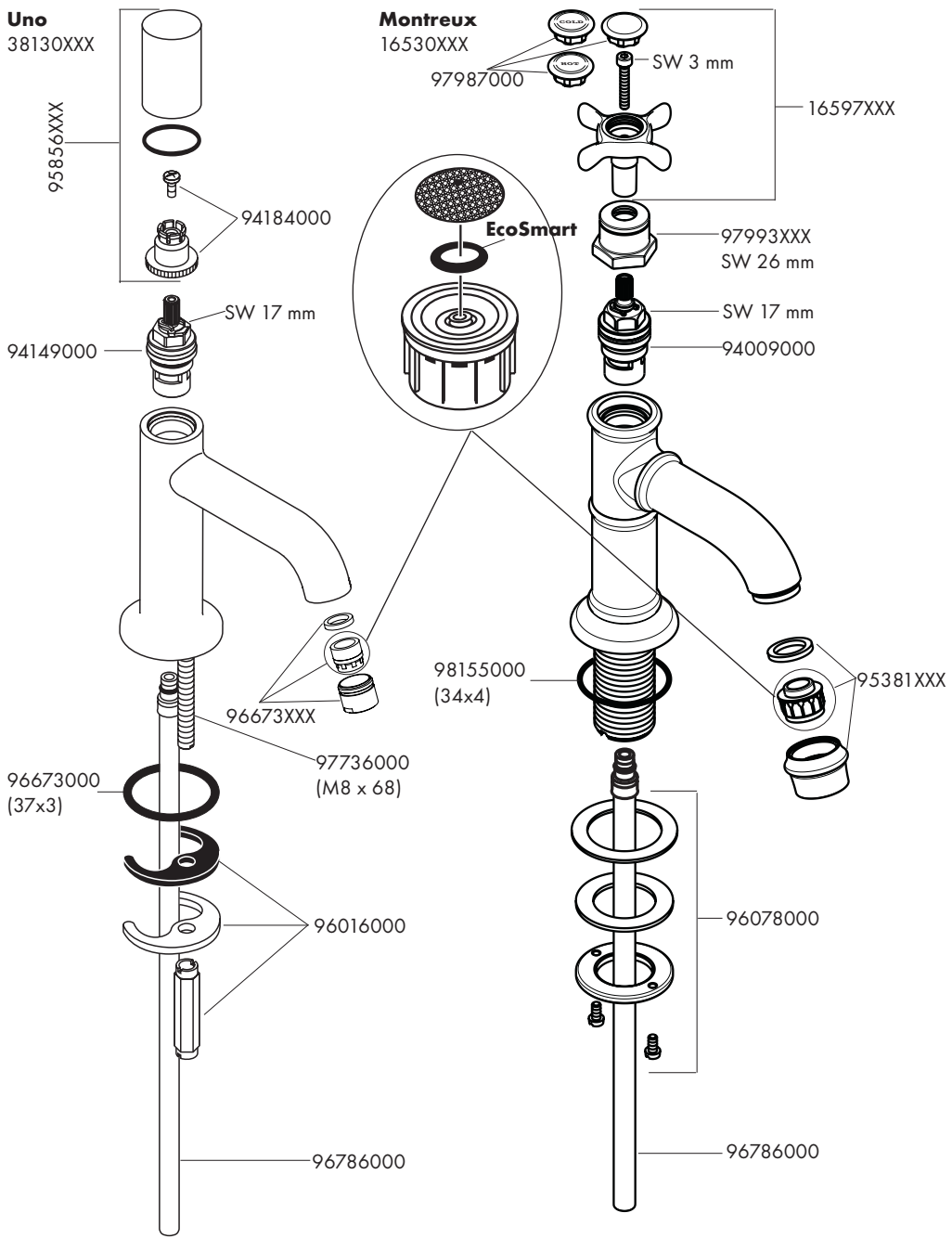

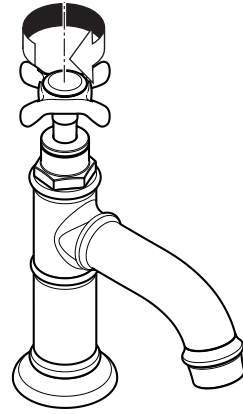
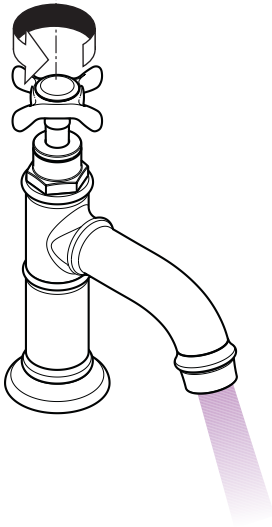

öffnen / ouvert / open / aperto / abierto / open / åbne /
 abrir / otworzyć / otevřít / otvoriť / 开 / открыть / nyitás /
 avaaaminen / öppna / atidaryti / Otvaranje / açmak /
 deschide / ανοικτό / odpreti / avage / atvērt /
 otvoriti / åpne / отварање / hare / فتح

schließen / fermé / close / chiudere / cerrar / sluiten /
 lukke / fechar / zamknąć / zavřít / uzavriť / 关 /
 закрыть / bezárás / sulkeminen / stänga / uždaryti /
 Zatvaranje / kapatmak / închide / κλειστό /
 zarpeti / sulgege / aizvērt / zatvori / lukke / затваряње /
 mbylle / إغلاق



P-IX DVGW SVGW ACS WRAS ETA



16530XXX P-IX 18196/1A

X X

38130XXX P-IX 9377/1O

X  1.41/18541 X

Montreux

16530XXX



Uno

38130XXX

