

Edition 11

51120010100 Bath tub mixer DN 15

PRODUCT



DRAWING

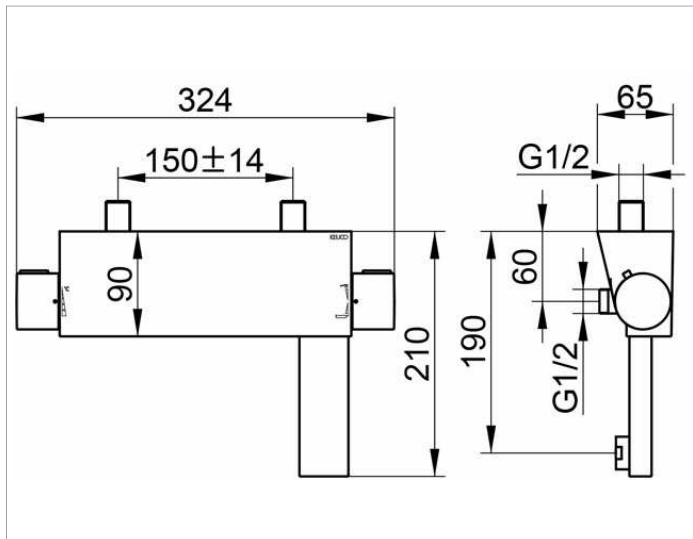

PRODUCT ATTRIBUTES

exposed
 ceramic stop valve and diverter,
 cartridge mixer with ceramic sealing gaskets,
 shower outlet connection DN 15
 (restricted flow rate 12 l/min),
 with backflow preventer,
 gauge 150 +/- 14 mm,
 suitable for combination boilers,
 aerator M 28x1,
 flow rate approx. 20 l/min.

SURFACE

chrome-plated

SPECIFICATIONS

KEUCO EDITION 11 single lever bath mixer DN 15 51120010100
 high-gloss chromed single lever bath mixer DN 15
 in clear-cut design and clear geometric shapes for surface mounting,
 high-quality cartridge with ceramic discs
 Hose connection DN 15, flow rate limited to 12 min l /,
 Protected against backflow
 Aerator M28 x 1
 suitable for water heater
 Height 65 mm, width 324 mm
 maximum radius 210 mm
 Gauge 150, tolerance class + / - 14 mm
 DVGW-test applied