

# VOLA T25

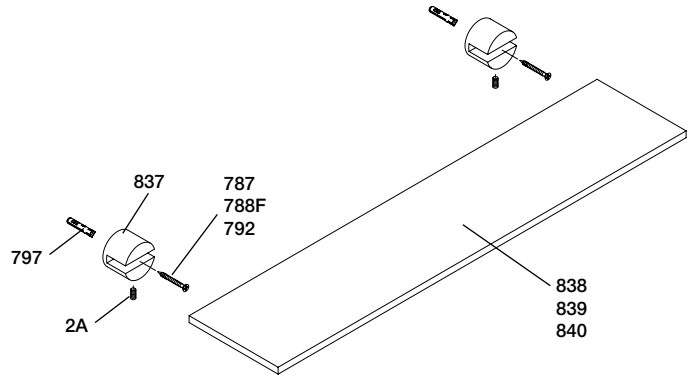

## VOLA T25

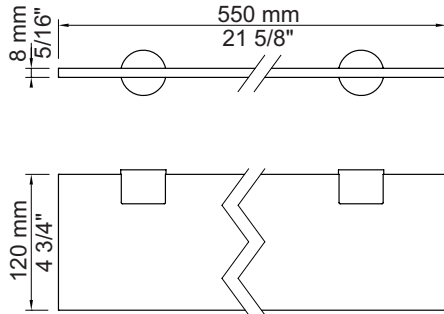

## VOLA T25HLD

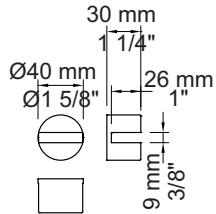

**Brug ikke sprit til rengøring af plexiglashylde!**

**Please do not use alcoholic cleaning detergent on acrylic shelves!**

**Bitte nicht die Acryglasplatten mit Spiritus abreiben!**

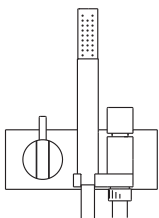
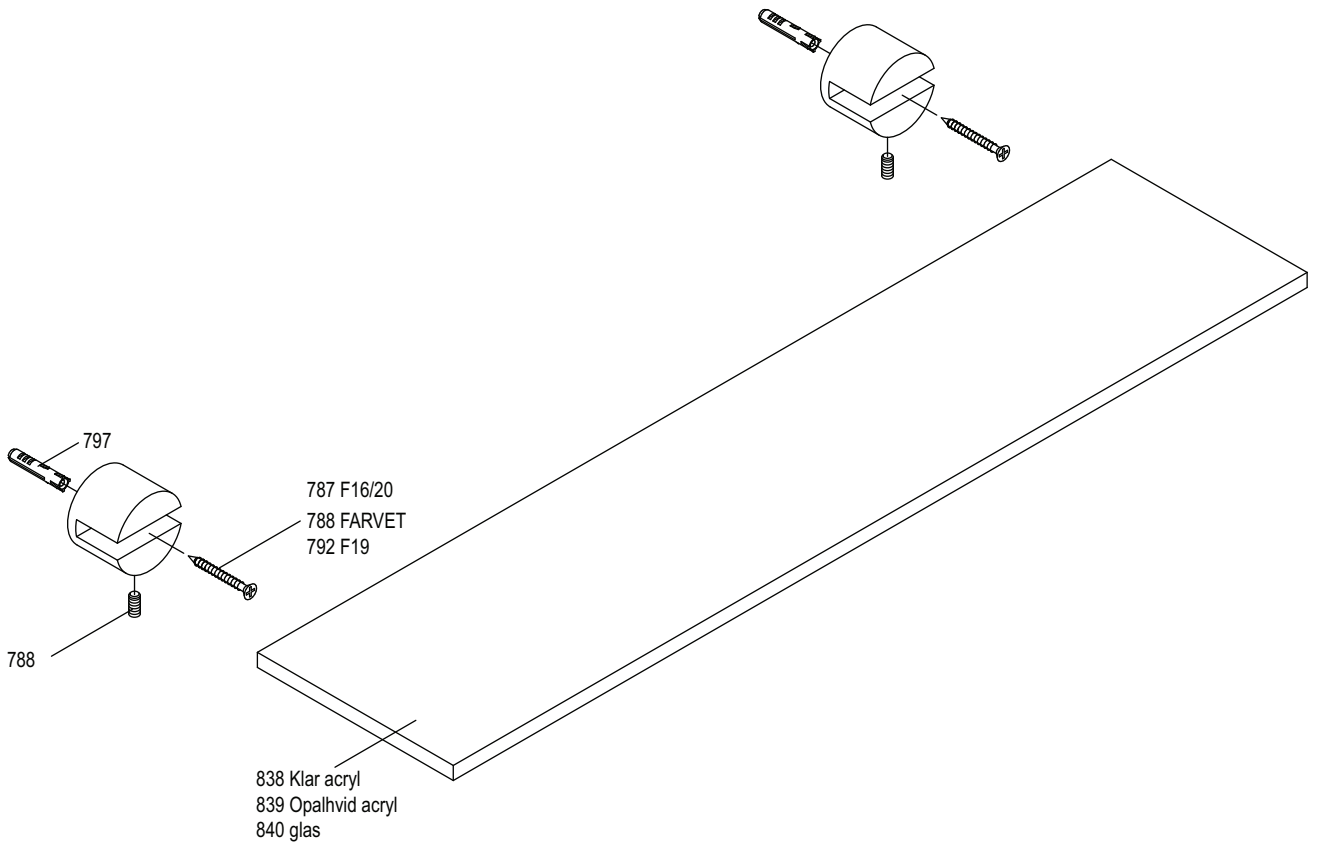

**VOLA A/S**  
 Lunavej 2  
 DK-8700 Horsens  
 Tlf : + 45 7023 5500  
 Fax: + 45 7023 5511  
 sales@vola.com  
 www.vola.com

## Vola T25

Dato

Jan. 84

Rev.

Blad

SB 42.16