

Date:

Client:

Project:

VOLA product: 874R



874R

Two-handle build-in mixer with ¼ turn ceramic disc technology and diverter. 874RUP = Build-in mixer 800TV. 874RAP = 2 pcs. handle NR17, handle NR19G, hand shower and hand shower holder with non-return valve 070R, hose 1500 mm, four-hole plate 60 x 309 mm 004.

Flow

	Bar:	1.0	2.0	3.0	4.0	5.0
070R	(l/min)	5.2	7.4	9.0	9.0	9.0
800TV	(l/min)	20.2	28.6	35.0	40.4	45.2

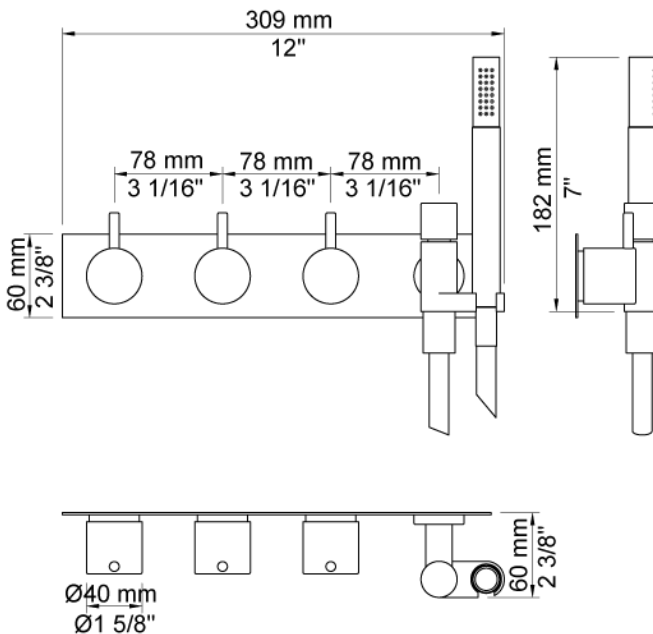

Available in colors

- Color 02, Grey
- Color 04, Light blue
- Color 05, Orange
- Color 06, Light green
- Color 08, Yellow
- Color 09, Dark grey
- Color 12, Mocca
- Color 14, Bright red
- Color 15, Dark blue
- Color 16, Polished chrome
- Color 17, Gloss black
- Color 18, White
- Color 19, Natural brass
- Color 20, Brushed chrome
- Color 21, Carmine red
- Color 25, Pink
- Color 27, Matt black
- Color 40, Brushed stainless steel

Date:

Client:

Project:

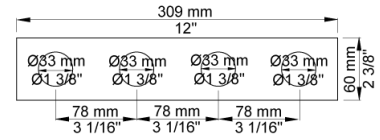

004
Four-hole plate, 60 x 309 mm. Holes Ø33 mm.

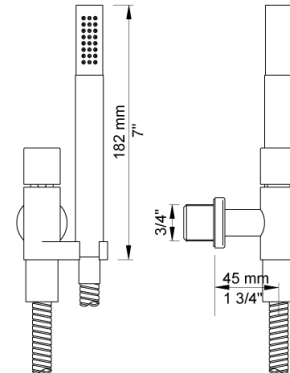

070R
Hand shower, hand shower with holder to the right and hose with non-return valve.

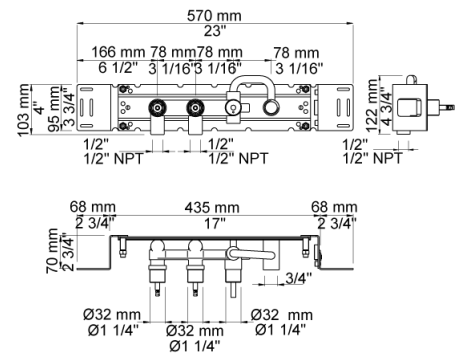
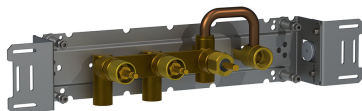

800TV
Two-handle build-in mixer with diverter, for bath filling and hand shower, with one pre-mounted outlet socket. 1/2" connection to copper, steel, iron or pex pipe work.

Date:

Client:

Project:



NR17
Operating handle for 600, 700, 800, 900, 1500, 2800, 2900, S20, S21, S40, S42 incl. variants. Ø40 mm.

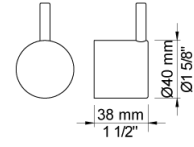

NR19G
Diverter handle for 400 and 800 incl. variants. Ø40 mm. With peg in the same colour as handle(standard).

