

Date:

Client:

Project:

VOLA product: 811C-071



811C-071

Two-handle build-in mixer with ¼ turn ceramic disc technology and diverter. 811C-071UP = Build-in mixer 800N. 811C-071AP = 2 pcs. handle NR17, handle NR19G, 160 mm fixed spout 010C, hand shower and hand shower holder with non-return valve 070, 5 pcs. 60 mm circular flanges 001.

Flow

	Bar:	1.0	2.0	3.0	4.0	5.0
010C	(l/min)	12.1	17.2	21.0	24.3	27.1
070	(l/min)	5.2	7.4	9.0	9.0	9.0

Available in colors

- Color 02, Grey
- Color 04, Light blue
- Color 05, Orange
- Color 06, Light green
- Color 08, Yellow
- Color 09, Dark grey
- Color 12, Mocca
- Color 14, Bright red
- Color 15, Dark blue
- Color 16, Polished chrome
- Color 17, Gloss black
- Color 18, White
- Color 19, Natural brass
- Color 20, Brushed chrome
- Color 21, Carmine red
- Color 25, Pink
- Color 27, Matt black
- Color 40, Brushed stainless steel

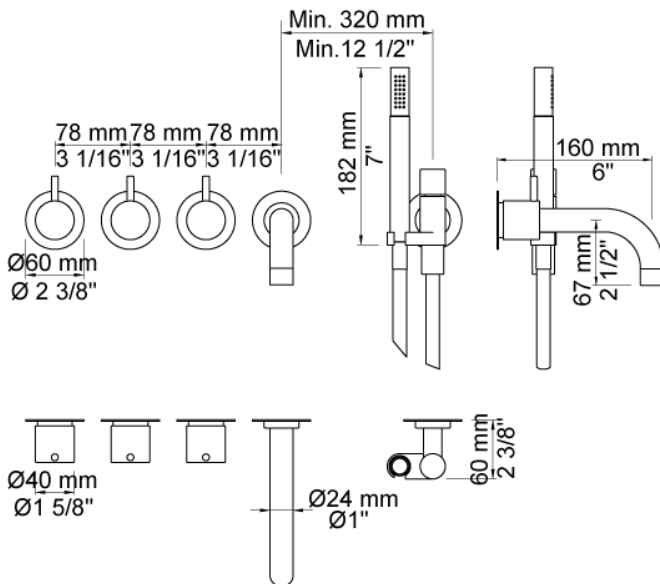

Date:

Client:

Project:

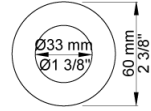

001
60 mm circular flange. Hole Ø33 mm.

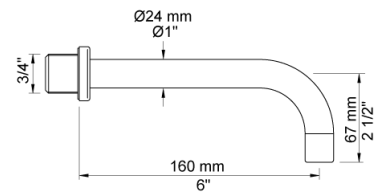

010C
160 mm fixed spout for high flow.

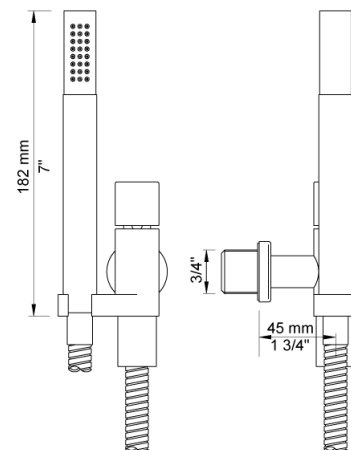

070
Hand shower, hand shower holder and hose with non-return valve.

