

Date:

Client:

Project:

VOLA product: 121/300



**121/300**

One-handle build-in mixer with ceramic disc technology. 121/300UP = Mixer 100. 121/300AP = Handle NR28, 300 mm spout 020/300, 60 mm circular flanges 001, 3001.

**Flow**

	<b>Bar:</b>	<b>1.0</b>	<b>2.0</b>	<b>3.0</b>	<b>4.0</b>	<b>5.0</b>
121/300	(l/min)	2.9	4.1	5.0	5.0	5.0
121/300 <sup>1)</sup>	(l/min)	2.6	3.7	4.5	4.5	4.5

<sup>1)</sup> USA standard

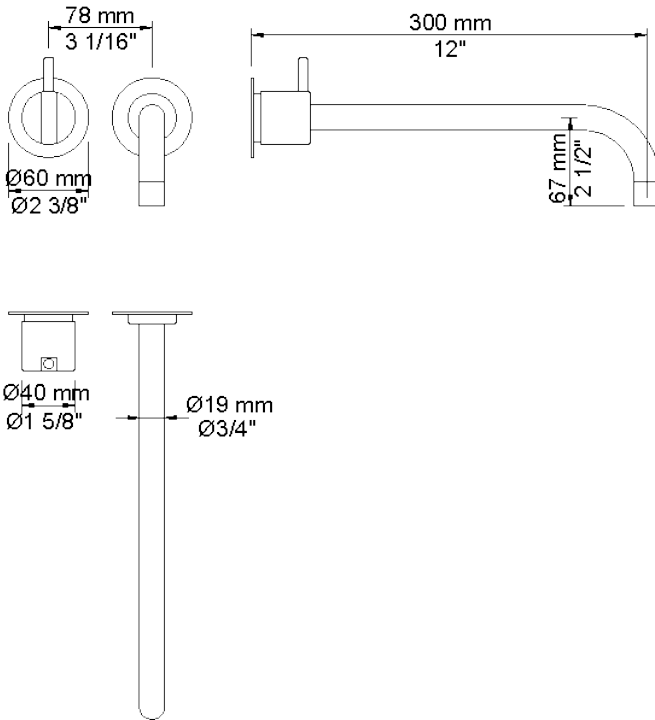

**Available in colors**

- Color 02, Grey
- Color 04, Light blue
- Color 05, Orange
- Color 06, Light green
- Color 08, Yellow
- Color 09, Dark grey
- Color 12, Mocca
- Color 14, Bright red
- Color 15, Dark blue
- Color 16, Polished chrome
- Color 17, Gloss black
- Color 18, White
- Color 19, Natural brass
- Color 20, Brushed chrome
- Color 21, Carmine red
- Color 25, Pink
- Color 27, Matt black
- Color 40, Brushed stainless steel

Date:

Client:

Project:

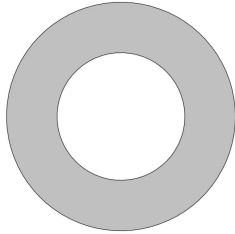

**001**  
60 mm circular flange. Hole Ø33 mm.

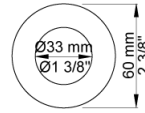

**020/300**  
300 mm fixed spout with water saving aerator.

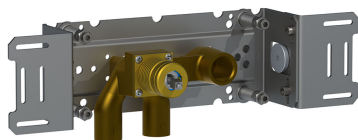
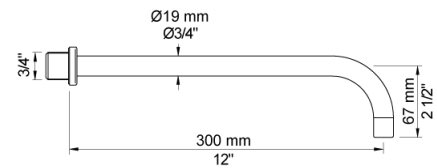

**100**  
One-handle build-in mixer with fixed outlet socket. 1/2" connection to copper, steel, iron or pex pipe work.

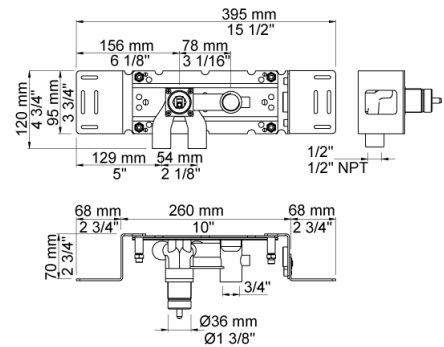

Date:

Client:

Project:

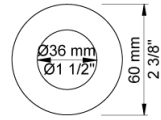

**3001**  
60 mm circular flange. Hole Ø36 mm.

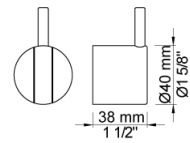

**NR28**  
Operating handle for 100, 200, 300, 400 incl. variants. Ø40 mm.