

Date:

Client:

Project:

VOLA product: 122L

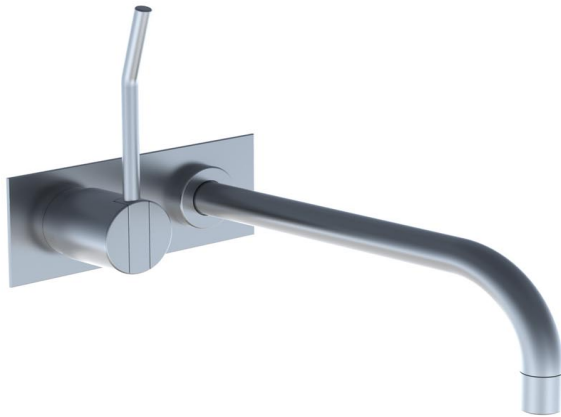

**122L**

One-handle build-in mixer with ceramic disc technology. 122LUP = Mixer 100. 122LAP = Handle NR28L, 225 mm spout 020, two-hole plate 60 x 153 mm 3002.

Ada approved.

**Flow**

	<b>Bar:</b>	<b>1.0</b>	<b>2.0</b>	<b>3.0</b>	<b>4.0</b>	<b>5.0</b>
122L	(l/min)	2.9	4.1	5.0	5.0	5.0
122L <sup>1)</sup>	(l/min)	2.6	3.7	4.5	4.5	4.5

<sup>1)</sup> USA standard

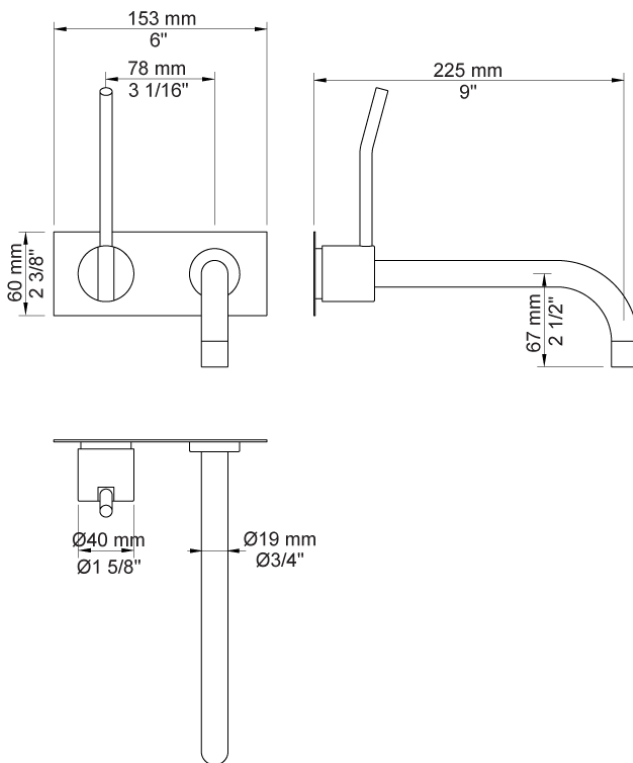

**Available in colors**

- Color 02, Grey
- Color 04, Light blue
- Color 05, Orange
- Color 06, Light green
- Color 08, Yellow
- Color 09, Dark grey
- Color 12, Mocca
- Color 14, Bright red
- Color 15, Dark blue
- Color 16, Polished chrome
- Color 17, Gloss black
- Color 18, White
- Color 19, Natural brass
- Color 20, Brushed chrome
- Color 21, Carmine red
- Color 25, Pink
- Color 27, Matt black
- Color 40, Brushed stainless steel



Date:

Client:

Project:



**020**  
225 mm fixed spout with water saving aerator.

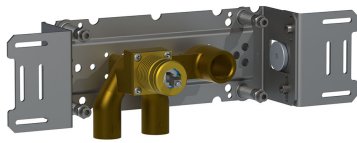
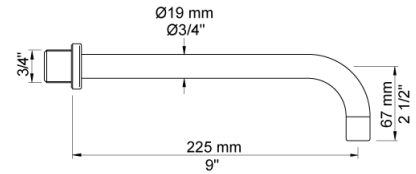

**100**  
One-handle build-in mixer with fixed outlet socket. 1/2" connection to copper, steel, iron or pex pipe work.

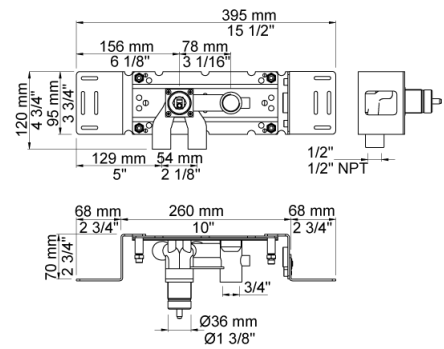

**3002**  
Two-hole plate, 60 x 153 mm. Holes Ø36 and Ø33 mm.

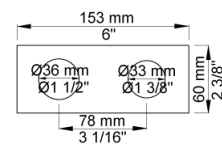

Date:

Client:

Project:



**NR28L**  
 Operating handle for 100, 200, 300, 400 incl. variants. Ø40 mm. Long lever.

