

Date:

Client:

Project:

VOLA product: 871R-081D

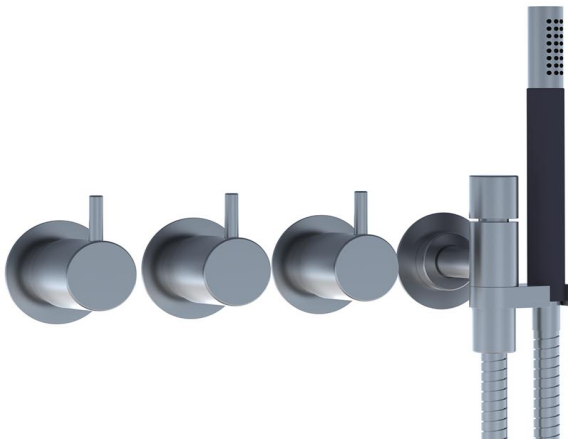

**871R-081D**

Two-handle build-in mixer with ¼ turn ceramic disc technology and diverter. 871R-081DUP = Mixer 800N. 871R-081DAP = 2 pcs. handles NR17, handle NR19G, hand shower and hand shower holder with non-return valve 070R, hose 1500 mm, double head shower 080D, 5 pcs. 60 mm circular flanges 001.

**Flow**

	Bar:	1.0	2.0	3.0	4.0	5.0
070R <sup>1)</sup>	(l/min)	5.2	7.4	9.0	9.0	9.0
080D <sup>2)</sup>	(l/min)	14.4	20.4	25.0	28.9	32.3

<sup>1)</sup> USA: Flow restricted to 1.8 gpm (7.0 l/min)

<sup>2)</sup> USA: Flow restricted to 1.8 gpm (7.0 l/min)

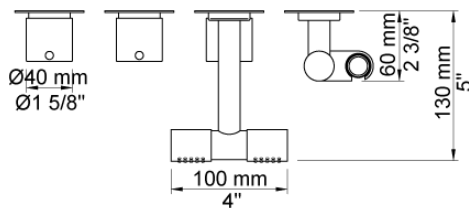
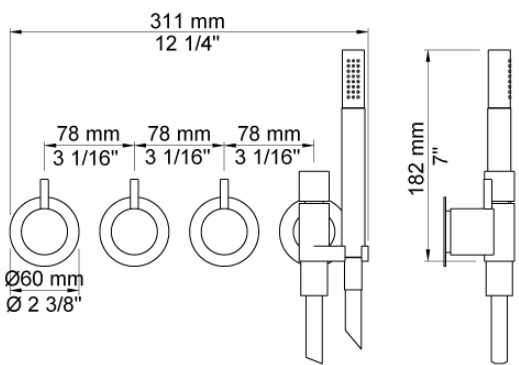
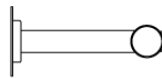
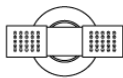

**Available in colors**

- Color 16, Polished chrome
- Color 20, Brushed chrome
- Color 40, Brushed stainless steel

Date:

Client:

Project:

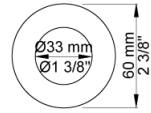

**001**  
60 mm circular flange. Hole Ø33 mm.

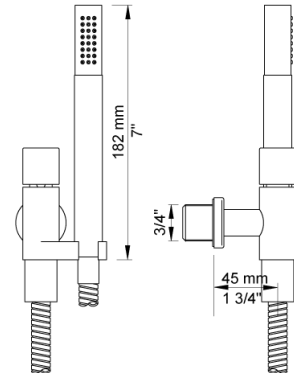

**070R**  
Hand shower, hand shower with holder to the right and hose with non-return valve.

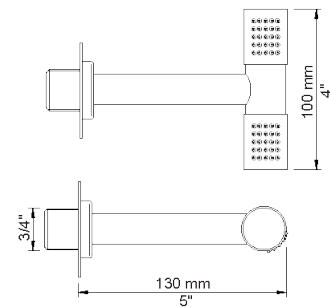

**080D**  
130 mm double head shower. 60 mm cover flange included.

Date:

Client:

Project:

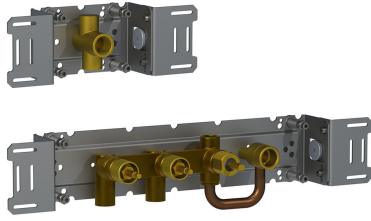

**800N**

Two-handle build-in mixer with diverter, including one fixed and one separate outlet socket, 200M. 1/2" connection to copper, steel, iron or pex pipe work.

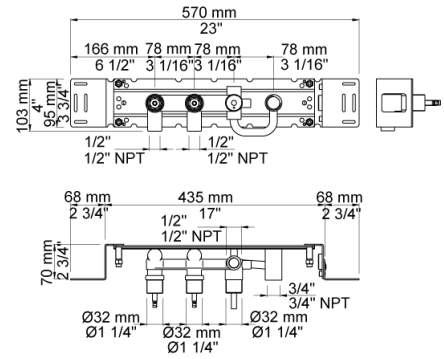

**NR17**

Operating handle for 600, 700, 800, 900, 1500, 2800, 2900, S20, S21, S40, S42 incl. variants. Ø40 mm.

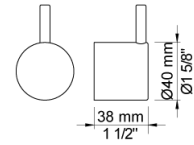

**NR19G**

Diverter handle for 400 and 800 incl. variants. Ø40 mm. With peg in the same colour as handle(standard).

