

Date:

Client:

Project:

VOLA product: 875S-081



**875S-081**

Two-handle build-in mixer with ¼ turn ceramic disc technology and diverter.875S-081UP = Mixer 800N.

875S-081AP = 2 pcs. handles NR17, handle NR19G, hand shower and hand shower holder with non-return valve 070S, hose 1500 mm, 115 mm head shower 080, five-hole plate 60 x 387 mm 005.

**Flow**

	Bar:	1.0	2.0	3.0	4.0	5.0
080 <sup>1)</sup>	(l/min)	6.9	9.8	12.0	13.9	15.5
070S <sup>2)</sup>	(l/min)	6.9	9.8	12.0	13.9	15.5

<sup>1)</sup> USA: Flow restricted to 1.8 gpm (7.0 l/min)

<sup>2)</sup> USA: Flow restricted to 2.0 gpm (7.6 l/min)

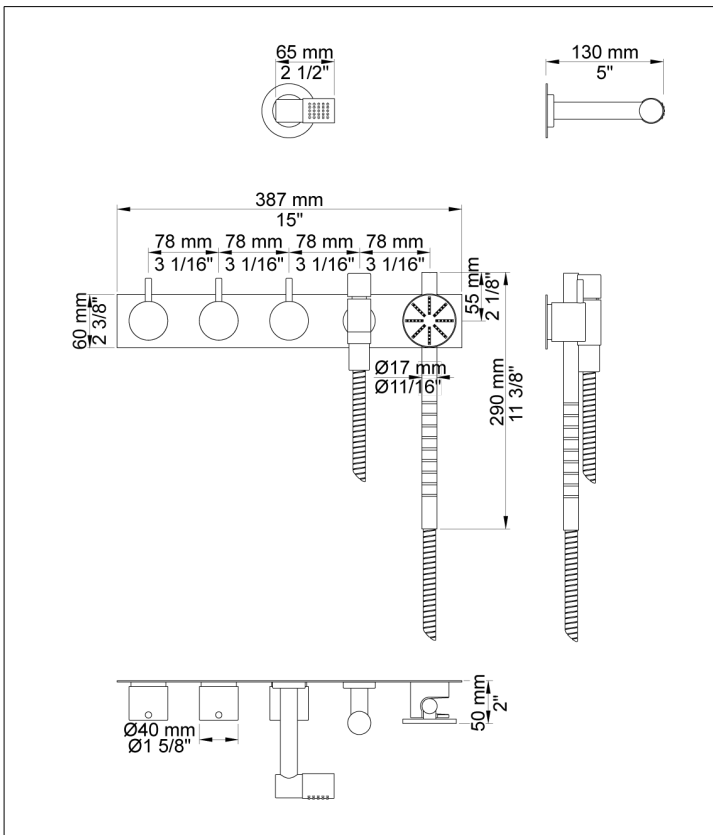

**Available in colors**

- Color 16, Polished chrome
- Color 19, Natural brass
- Color 20, Brushed chrome
- Color 40, Brushed stainless steel

Date:

Client:

Project:

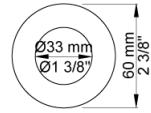
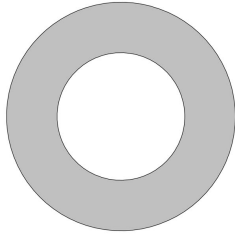

**001**

60 mm circular flange. Hole Ø33 mm.



**070S**

Hand shower, hand shower holder and hose with non-return valve.

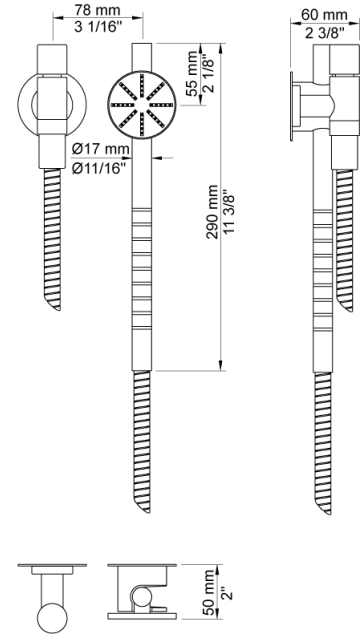

**080**

130 mm head shower. 60 mm cover flange included.

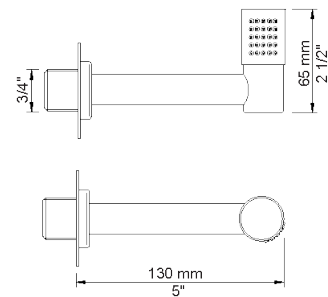

Date:

Client:

Project:

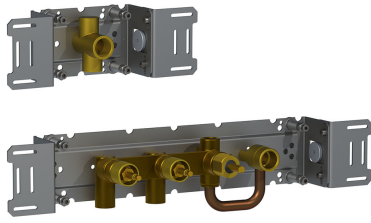

**800N**

Two-handle build-in mixer with diverter, including one fixed and one separate outlet socket, 200M. 1/2" connection to copper, steel, iron or pex pipe work.

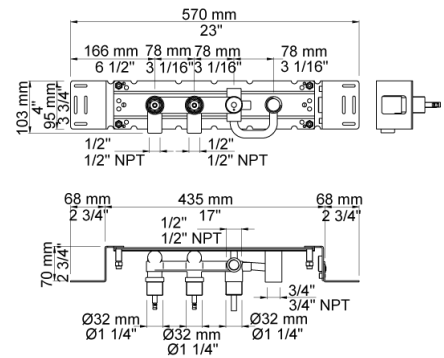

**NR17**

Operating handle for 600, 700, 800, 900, 1500, 2800, 2900, S20, S21, S40, S42 incl. variants. Ø40 mm.

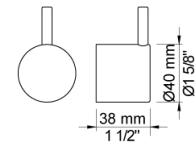

**NR19G**

Diverter handle for 400 and 800 incl. variants. Ø40 mm. With peg in the same colour as handle(standard).

