

Aura Pedestal A1

Front View

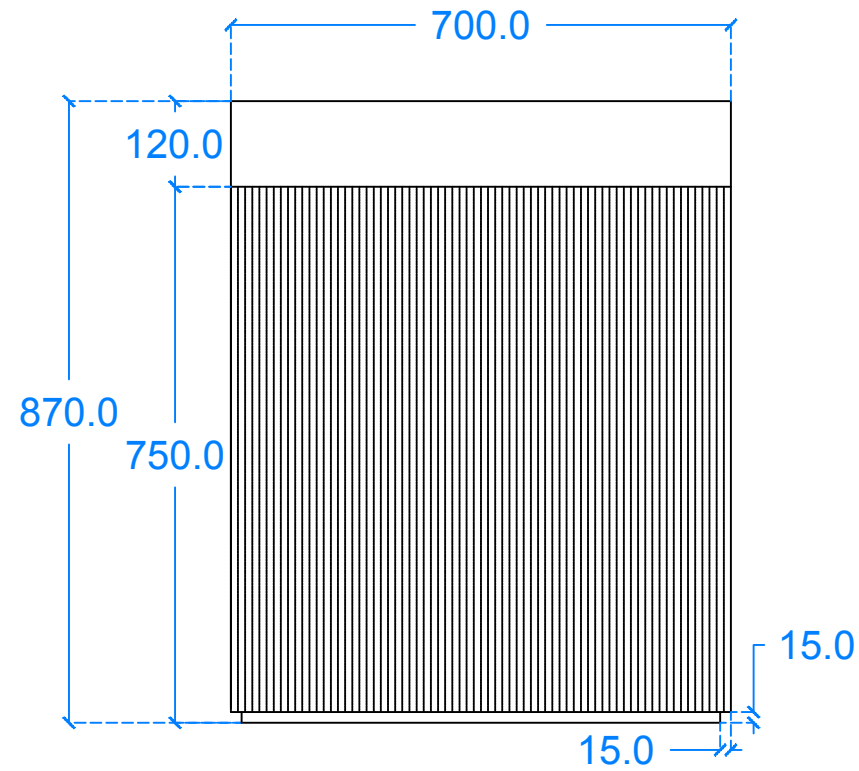

Side View

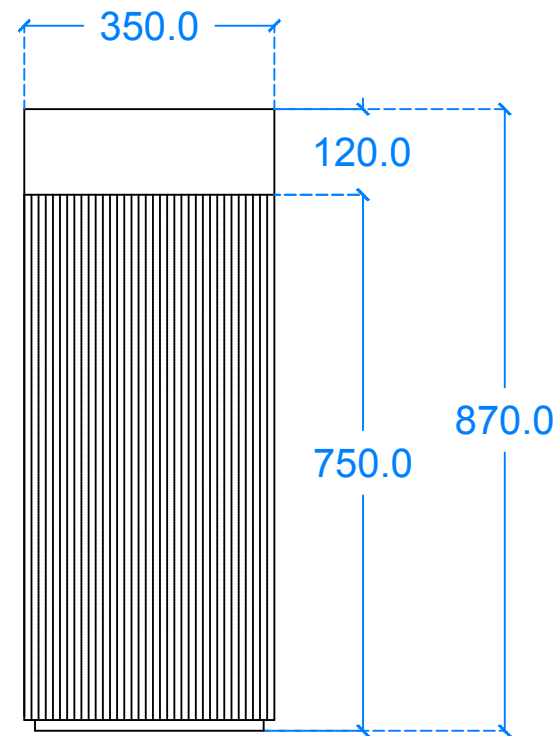

Back View

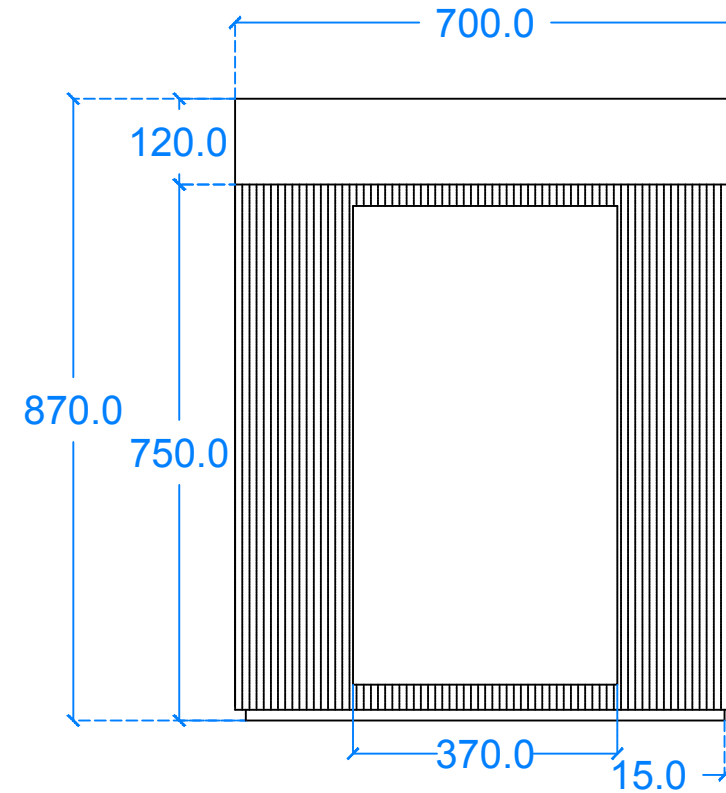

Plan View

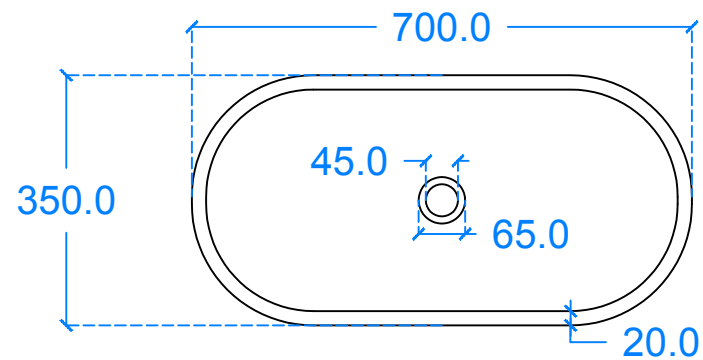

Section A-A

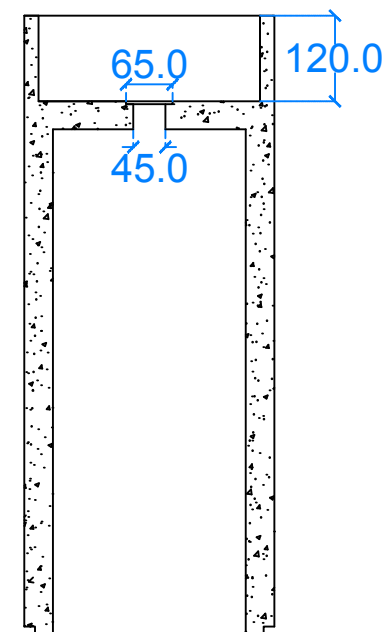

Underside View

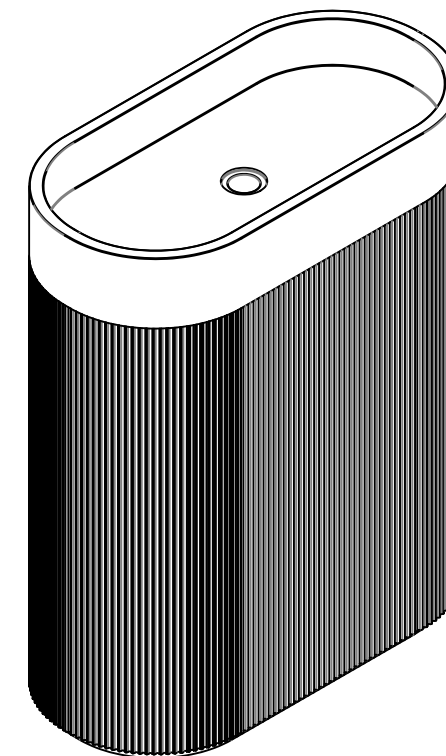
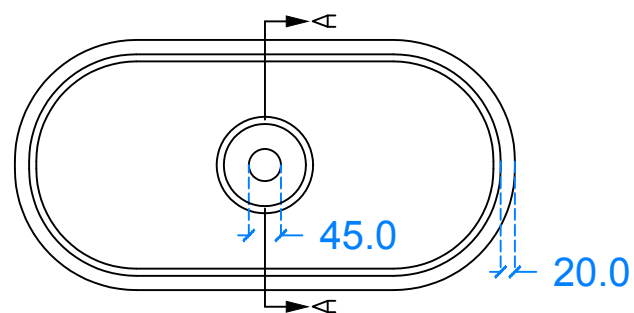

General notes

Kast work to tolerances of +/-5mm, Joints 3-5mm, vertical deflection 3mm per linear meter. It is the responsibility of the recipient (client) to check all dimensions are correct and confirm this prior to manufacture. Kast will manufacture only from these drawings on receipt of client confirmation and takes no responsibility for incorrect dimensions and measurements not reported. This drawing is to be viewed in conjunction with all other contract documentation and specifications, and all other consultants drawings. All dimensions should be checked and any discrepancies notified to Kast prior to proceeding with works. Any discrepancies found between this drawing and other documents should be referred immediately to Kast. The author takes no responsibility for any dimensions obtained by scaling from this drawing.

Basin Description
L700 x W350 x H870 mm
20mm walls

Weight 150kg/330lbs	Scale N/A	Drawn by J.F
------------------------	--------------	-----------------

Basin Code AP.A1

Unless otherwise stated, dimensions are in mm

Kast

Kast Concrete Basins Ltd

2 - 4 Meden Court

Boughton Industrial Est

Nottingham NG22 9YU

Tel +44 (0)1623 709249

Email info@kastconcretebasins.com

Web www.kastconcretebasins.com