

Edition 400

21532171331 Mirror cabinet

PRODUCT



DRAWING

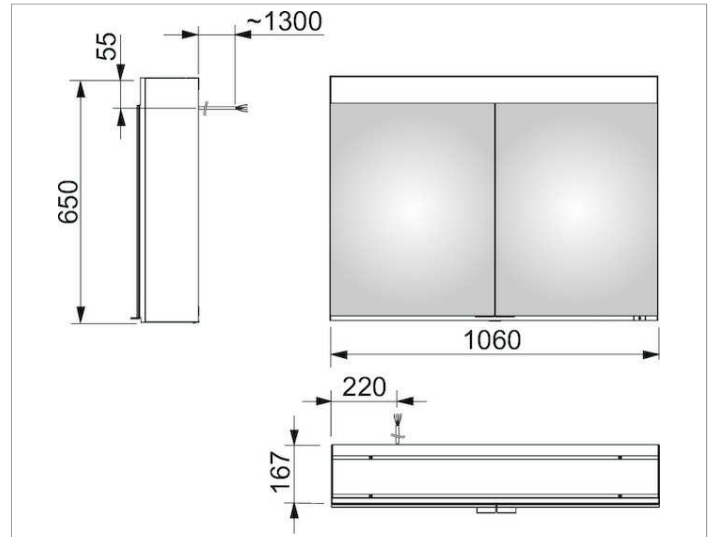

PRODUCT ATTRIBUTES

wall mounted,
 1 light colour, 4000 kelvin (neutral white)
 2 hinged double sided crystal mirrored doors,
 Body: aluminium silver anodized
 Body panels made from rear-lacquered white glass
 interior rear wall mirrored
 Operation:
 key panel with capacitive touch sensor,
 optional to be operated via the light switch
 Illumination:
 LED 39 watt (lifespan > 30.000 hours)
 infinitely dimmable, lamps non-exchangeable
 EEK: A++, A+, A , 39 kWh/1000h

EQUIPMENT

- 1 shaver socket
- 2 x 3 adjustable glass shelves
- 2 storage boxes with slidable glass lid
- interior lighting
- soft-closing doors

SURFACE

silver anodized

DIMENSION

1060 x 650 x 167 mm